

Tuesday April 18, 2017

**BOARD OF DIRECTORS
AMADOR FIRE PROTECTION DISTRICT
COUNTY ADMINISTRATION CENTER**

810 Court Street
Jackson, California 95642

AGENDA

-- 11:00 a.m. --

Please Note: All Board of Directors meetings are recorded.

In compliance with the Americans with Disabilities Act, if you are a disabled person and you need a disability-related modification or accommodation to participate in this meeting, please contact the Clerk of the Board staff, at (209) 223-6391 or (209) 223-6646(fax). Requests must be made as early as possible and at least one-full business day before the start of the meeting. Assisted hearing devices are available in the Board Chambers for public use during all public meetings.

Pursuant to Government Code 54957.5, all materials relating to an agenda item for an open session of a regular meeting of the Board of Directors which are provided to a majority or all of the members of the Board by Board members, staff or the public within 72 hours of but prior to the meeting will be available for public inspection, at and after the time of such distribution, in the office of the Clerk of the Board of Directors, 810 Court Street, Jackson, California 95642, Monday through Friday, between the hours of 8:00 a.m. and 5:00 p.m., except for County holidays. Materials distributed to a majority or all of the members of the Board at the meeting will be available for public inspection at the public meeting if prepared by the members of the Board or District staff and after the public meeting if prepared by some other person. Availability of materials related to agenda items for public inspection does not include materials that are exempt from public disclosure under Government Code sections 6253.5, 6254, 6254.3, 6254.7, 6254.15, 6254.16, or 6254.2.

PLEDGE OF ALLEGIANCE

AGENDA: Off-agenda items must be approved by the Board pursuant to Section 54954.2 of the Government Code.

PUBLIC MATTERS NOT ON THE AGENDA: Discussion items only; no action will be taken. Any person may address the Board at this time upon any subject within the jurisdiction of the AFPD Board of Directors; however, any matter that requires action may be referred to staff and/or Committee for a report and recommendation for possible action at a subsequent Board meeting. **Please note - there is a five (5) minute limit per topic.**

ADMINISTRATIVE MATTERS

- (1) UPDATE - CHANGE IN PROCEDURE FOR BENEFIT ASSESSMENT:** Discussion and possible action regarding assessing contiguous parcels during benefit assessments. Additional information to be provided by County Counsel.
- (2) VEHICLE MAINTENANCE REPORT:** Report of expenses for maintenance and repair of District vehicle fleet and update regarding feasibility of a district mechanic.
- (3) FEASIBILITY STUDY FOR DISPATCHING SERVICES:** Discussion and possible action regarding the cost of a feasibility study for dispatching services provided by Sacramento Regional EMS Communication Center. Update to Board regarding requested information from prior meeting of 03/22/2017.

(4) CATASTROPHIC LEAVE POLICY: Discussion and possible action on adopting a Catastrophic Leave policy.

(5) PURCHASE OF FIRE APPARATUS: Discussion and possible action regarding the purchase of a 2017 Rosenbauer Type 1 Engine.

(6) SELF CONTAINED FUEL TANK FOR STATION 112: Discussion and possible action relative to the placement of a 1,000 gallon fuel tank at station 112.

MISCELLANEOUS MATTERS

(7) MINUTES: Review and approval of the regular minutes of the Board of Directors meeting of March 22, 2017, as presented or revised.

SCHEDULE NEXT MEETING

ADJOURNMENT

AGENDA TRANSMITTAL FORM

To: Amador Fire Protection Board of Directors

Date: 04/18/2017

From: David Bellerive Phone Ext. 391
 (Department Head - please type)

<input checked="" type="checkbox"/>	Regular Agenda
<input type="checkbox"/>	Consent Agenda
<input type="checkbox"/>	Blue Slip
<input type="checkbox"/>	Closed Session
Meeting Date Requested:	
<u>04/18/2017</u>	

Department Head Signature *David Bellerive*

Agenda Title: UPDATE - CHANGE IN PROCEDURE FOR BENEFIT ASSESSMENT

Summary: (Provide detailed summary of the purpose of this item; attach additional page if necessary)

Discussion and possible action regarding assessing contiguous parcels during benefit assessments. Additional information to be provided by County Counsel.

Recommendation/Requested Action:
None

Fiscal Impacts (attach budget transfer form if appropriate) None Staffing Impacts None

Is a 4/5ths vote required? Yes No

Contract Attached:	Yes <input type="checkbox"/>	No <input type="checkbox"/>	N/A <input checked="" type="checkbox"/>
Resolution Attached:	Yes <input type="checkbox"/>	No <input type="checkbox"/>	N/A <input checked="" type="checkbox"/>
Ordinance Attached:	Yes <input type="checkbox"/>	No <input type="checkbox"/>	N/A <input checked="" type="checkbox"/>
Comments: _____			

Committee Review? N/A
 Name _____
 Committee Recommendation: _____

Request Reviewed by:

Chairman _____ Counsel _____
 Auditor _____ GSA Director _____
 CAO _____ Risk Management _____

Distribution Instructions: _____

FOR CLERK USE ONLY

Meeting Date 4-18-17 Time 11:00am Item # 1

Board Action: Approved Yes ___ No ___ Unanimous Vote: Yes ___ No ___
 Ayes: _____ Resolution _____ Ordinance _____ Other: _____
 Noes: _____ Resolution _____ Ordinance _____
 Absent: _____ Comments: _____

Distributed on _____ Completed by _____	A new ATF is required from _____ Department _____ For meeting _____ of _____	I hereby certify this is a true and correct copy of action(s) taken and entered into the official records of the Amador Fire Protection District. ATTEST: _____ AFPD Board Clerk
--	---	--

AGENDA TRANSMITTAL FORM

To: Amador Fire Protection Board of Directors

Date: 04/18/2017

From: David Bellerive Phone Ext. 391
(Department Head - please type)

Department Head Signature *David Bellerive*

<input checked="" type="checkbox"/>	Regular Agenda
<input type="checkbox"/>	Consent Agenda
<input type="checkbox"/>	Blue Slip
<input type="checkbox"/>	Closed Session
Meeting Date Requested:	
<u>04/18/2017</u>	

Agenda Title: VEHICLE MAINTENANCE REPORT

Summary: (Provide detailed summary of the purpose of this item; attach additional page if necessary)

Report of expenses for maintenance and repair of District vehicle fleet, and update regarding feasibility of a district mechanic.

Recommendation/Requested Action: <u>Review attached report</u>	
Fiscal Impacts (attach budget transfer form if appropriate) <u>None</u>	Staffing Impacts <u>None</u>
Is a 4/5ths vote required? Yes <input type="checkbox"/> No <input checked="" type="checkbox"/>	Contract Attached: Yes <input type="checkbox"/> No <input type="checkbox"/> N/A <input checked="" type="checkbox"/> Resolution Attached: Yes <input type="checkbox"/> No <input type="checkbox"/> N/A <input checked="" type="checkbox"/> Ordinance Attached: Yes <input type="checkbox"/> No <input type="checkbox"/> N/A <input checked="" type="checkbox"/> Comments: _____ _____
Committee Review? Name _____ N/A <input checked="" type="checkbox"/>	
Committee Recommendation: _____ _____	

Request Reviewed by:

Chairman _____	Counsel _____
Auditor _____	GSA Director _____
CAO _____	Risk Management _____

Distribution Instructions: _____

FOR CLERK USE ONLY

Meeting Date 4-18-17 Time 11:00am Item # 2

Board Action: Approved Yes ___ No ___ Unanimous Vote: Yes ___ No ___

Ayes: _____ Resolution _____ Ordinance _____ Other: _____

Noes _____ Resolution _____ Ordinance _____

Absent: _____ Comments: _____

Distributed on _____	A new ATF is required from _____ Department _____	I hereby certify this is a true and correct copy of action(s) taken and entered into the official records of the Amador Fire Protection District.
Completed by _____	For meeting of _____	ATTEST: _____ AFPD Board Clerk

Vehicle Description	VIN License Number	Odometer Reading	Repair Hours / Comments (out of service, Misc, etc. if applicable)	Dates	Maintenance Performed (description)	MARCH Total Cost this Month	Current Total Cost Accumulative 16/17FY
5100 - Chief 2015 Ford Explorer	1FM5K8R7FGB25939 (E) 1460509	17,283		7/19/16 12/20/2016	Lynch's - A Service (\$148.17) Stein's Auto - A & B Service (\$77.09)	\$0.00	\$225.26
5101 - Chief 2010 Ford Expedition XL T 4x4	1FMUJUG59AEA43199 (E) 1305976	156,335		10/4/2016 11/8/2016 1/17/2017 2/7/17 3/7/17 -	US Bank/Jackson Express - A Service (\$48.46) US Bank - Snow Chains (\$78.61) GSA Motorpool - labor for repairing seats (\$366.00) Tractor Supply - Rear Back-Up Lights (\$76.13) Steins - B svc. & Brake Caliper, Pad, & Rotor, L. rear hub and bearing assy (\$1519.51)	\$1,519.51	\$2,088.71
5103 - Chief 2016 Ford F250 Supercab 4x4	1FT7X2B60CEA6410 (E) 1485648	16,189		8/9/2016 8/16/2016 8/16/2016 11/8/2016 03/28/17	Steins - A Service (\$81.08) Riebes - Torque Wrench/Parts (\$29.14) Riebes - Engine Oil / Parts (\$43.28) Riebes - Maintenance Parts (solenoid, test leads, wiring, etc.) (\$79.87) Steins - B Maintenance Service (\$82.49)	\$82.49	\$315.86
5104 - Chief 2011 Ford F250 4x4 Pick-Up	1FT7X2B62BEA30761 (E) 1306800	88,640		7/19/16 - 12/13/2016	Lynch's - Rple front brakes, rotors, calipers, rear brake pads, bleed entire system & reset ABS (\$1226.46) Riebes - Accufit Conventional (\$22.57)	\$0.00	\$1,249.03
5105 - Chief 2012 Ford Expedition 4x4	1FMUJUG5XCCE67187 (E) 1401123	64,450		12/6/2016 12/13/2016 1/10/17	Jackson Tires - 4 New Tires (\$1170.00) Stein's - B Maintenance Service (\$138.93) US Bank/DDM Tuning - Head Light Bulbs (\$87.99)	\$0.00	\$1,396.92
5106 - Chief 2009 Ford F250 4x2 Pick-Up	1FTSX2J569EA15399 (E) 1294991	63,067		9/6/16 11/29/2016 1/10/17 1/17/17	D. Veerkamp - Rple rotors, calipers and pads on both sides (\$711.42) Steins Auto - B Maintenance Service (\$81.08) Riebes - Lift Support (\$47.50) Jackson Tire - 4 New Tires (\$838.13)	\$0.00	\$1,678.13
5108 - Chief 2002 Ford Expedition	1FMZU73E02ZB09571 (E) 1178037	62,000		10/4/2016 03/28/17 -	Steins Auto - B Service (\$84.11) Steins Auto - C Service, Window Motor, Antilock Brakes, Cruise Control & Overhead lights (\$894.96)	\$894.96	\$979.07
Rescue 1 1999 Ford F350 Rescue Truck	1FDWE378XEBB48328 (E) 1013917	79,508		7/19/16 8/16/16 9/27/16 11/29/2016	Pine Grove Tire - Tire Repair (\$20) Riebes - LED light/Grommet (\$23.71) J&H Auto - B Service (\$471.27) J&H Auto - 2 new 7565 batteries (\$299.72)	\$0.00	\$814.70

Vehicle Description	VIN License Number	Odometer Reading	Repair Hours / Comments (out of service, Misc., etc. if applicable)	Dates	Maintenance Performed (description)	MARCH Total Cost this Month	Current Total Cost Accumulative 16/17FY
E-141 2003 HME Fire Truck	4AKFT42823WZ20034 {EJ}1159077	78,786		7/26/16 8/9/2016 8/16/2016 8/16/2016 8/30/2016 9/13/16 9/13/16 9/13/16	Fire.Com - Wireless Headset Repair (\$172.80) J&H Auto - Rear Brakes Out of Adjustment (\$149.19) Riebes - Radiator Cap (\$6.47) Riebes - Engine Oil (\$31.30) D. Veerkamp - Power Steering High Pressure Hose Assembly (\$252.90) ATR - Transport Engine to D. Veerkamps from Station 114 (\$618.75) Riebes - Peak Ready to Use (\$11.87) D. Veerkamp - Rplc Power Steering Gear Box / Made New PS Hose (\$1789.24) Riebes - Maintenance Parts (\$220.93) Riebes - Oil, Filter, etc. (\$75.65) ATR - Tow (Ditch/Stuck in Mud) (\$500) Riebes - Emergency Light (\$56.12) Riebes - Brass Starter/Switch (\$77.50) Riebes - Electrical Auto Parts (\$43.14) Burton's Fire - Annual Pump Testing/Vacuuum Testing (\$303.33) TruckNTow - Snow Chains/Cables (\$107.02) Riebes - Coolant, Fuse, Oil (\$90.06) Doug Veerkamp - A service, Rpl starter, p/s pump, rear brakes & drums, rpl aux. steering gear box (\$5950.63) L.N. Curtis - Various Valve Rebuild Kits due to leak (\$168.09) D. Veerkamp - Rear Brakes and Park Brake Adjustment (\$283.72)	\$451.81	\$10,908.71
SO-145 2003 Ford F350 4X4	HFDWE37P23ED60337 {EJ}1159107	41,936		9/27/16 12/13/2016	J&H Auto - B Service (\$482.31) O'Reilly's - Hood Sturts Worn - Replaced (reimbursement from Keith) (\$43.18)	\$0.00	\$525.49
WT-146 1996 Int'l Model 4900 Chassis	1H1TSDADR7TH397632 {EJ} 035872	37,209		7/12/16 9/6/2016	Guy's Saw - Air Cleaner for Honda Pump (\$11.86) Jackson Tire - 2 Front Tires (\$1074.91)	\$0.00	\$1,086.77
5210 2000 Ford Utility Truck	HFMFPU16LXYL84751 {EJ} 1022891	106,906				\$0.00	\$0.00

Vehicle Description	VIN License Number	Odometer Reading	Repair Hours / Comments (out of service, Misc., etc. if applicable)	Dates	Maintenance Performed (description)	MARCH Total Cost this Month	Current Total Cost Accumulative 16/17FY
E-5221 (E222) 2003 HME Fire Truck	4KFT42R42WZ20025 (E) 1159078	93,412		7/12/2016 7/19/2016 8/9/2016 8/16/2016 8/16/2016 8/23/2016 10/4/2016 10/4/2016 10/18/2016	Ferguson Enterprise - Pipe Repairs (\$36.31) Riebes - ST/T Lamp (\$45.67) Rory's - Recharge A/C (\$148.73) Riebes - Headlight (\$21.59) Riebes - Bulb / Light Parts (\$56.30) D. Veerkamp - Pump Bulb/Labor/Replace Power Steering Pump (\$1204.46) Jackson Tire - 2 Front Tires (\$1468.43) US Bank/Amazon - Push Pull Parking/Emergency (\$35.68) Rorys - Rplc leaking park brake control switch (we supplied part-see above) (\$190) Riebes - Fuel Cap (\$36.71) Riebes - Maintenance Parts (\$83.97) D. Veerkamp - rplc valve and air leak at rear of truck above air tank (\$659.02)		\$6,988.04
				10/30/2016 11/8/2016 11/22/2016	Riebes - Fuel Cap (\$36.71) Riebes - Maintenance Parts (\$83.97) D. Veerkamp - rplc valve and air leak at rear of truck above air tank (\$659.02)		\$2,030.71
				11/29/2016 1/3/17 1/10/17 1/31/17 1/31/17 2/14/17 2/14/17 3/21/17	Burtons Fire - Electronic Vernier Throttle (\$467.78) Jackson Tire - Repair Rear Inner Tire, Tire Repair & Brass Valve System DOS:10/26 (\$33.87) Riebes - Oil (\$56.12) Burton's Fire - Annual Pump Testing/Vacuum Testing (\$303.33) Riebes - LED Clear Back Up Light (\$51.70) Riebes - Maintenance Parts (\$23.68) Riebes - Peak Global Lifetime Parts (\$33.98) Jackson Tire - 4 11R225 Goodyear Tires (\$2030.71)		\$816.31
E-222 1991 KME 1250 GPM Pumper 4x2	1HTSDPCR0N1H16111 (E) 340698	53,698		1/31/2017 3/28/17	Burton's Fire - Annual Pump Testing/Vacuum Testing (\$303.33) D. Veerkamp - B Svc. & Chassis Inspection (\$512.98)	\$512.98	\$816.31
E-223 1998 Int'l Fire Truck	1HTSDADR6WH551543 (E) 995299	36,492		8/23/2016 2/7/17 2/28/17	D. Veerkamp - A Service (\$2093.08) RiverView Int'l Trks - Valve Break Part (\$346.73) D. Veerkamp - A Service, Misc. Inspection, R&R Rear Drums (\$1414.44)	\$0.00	\$3,854.25

Vehicle Description	VIN License Number	Odometer Reading	Repair Hours / Comments (out of service, Mile., etc. if applicable)	Dates	Maintenance Performed (description)	MARCH Total Cost this Month	Current Total Cost Accumulative 16/17FY
E-5364 (6841) JRRCR 2008 FT Ford	1FD4W57R38EC53893 (E) 1356272	32,050		9/27/16 10/25/2016 10/25/2016 10/30/2016 10/30/2016 10/30/2016 10/30/2016 11/8/16 12/6/2016 - 12/13/16 - 12/31/16	D. Williams Equip - Broken Axels (\$4027.07) ATR - Tow from Pine Grove Market to Robert Hahns (\$500) Hahns Auto - Not Starting/Rp/e EGT Sensor & Update PCM (\$588.98) Riebes - Exhaust Wrap & Heat Spray (\$37.78) Riebes - Mini Clamp, Hydraulic Hose (\$13.40) Riebes - Bracket, Grommet, LED Clear Back Up, Pigtail (\$78.32) Riebes - Air Filter (\$72.65) Riebes Auto - Maintenance Parts (\$20.19) Burton's Fire - Ball Swivel to do inhouse repair for hard starting/running rough (\$40.94) Hahn's Automotive - Radiator Problems/Repair w/ new hoses, thermostat assy, etc. (\$1980.21) D. Veerkamp - aux engine - rplc muffler and fuel solenoid w/ parts supplied by AFPPD. Changed oil, check hard start, etc. (\$331.71) Burton's Fire - New aux. pump parts (\$1328.43)	\$0.00	\$9,019.68
E-5368 (6841) JRRCR 2007 FT EONE	4ENGAAA8371002458 (E) 1356273	57,532		7/19/16 7/19/16 8/16/2016 8/16/2016 8/16/2016 8/16/2016 9/13/2016 9/13/2016 11/8/16 1/24/17 2/7/17 - 3/7/17 3/21/17	Riebes - LED Clear Back Up Light (\$51.82) Riebes - Radiator Caps & Coolant (\$29.68) Riebes - Clamp on (\$15.11) Riebes - Cross View Convex & Electronic Cleaner Lit from SAC (\$38.10) Riebes - Lamp (\$18.13) Riebes - Keyless (\$8.62) Riebes - Engine Oil / Spray (\$25.02) Riebes - Coolant (\$23.75) Burtons Fire - Cab lift motor and seatbelt replacement (\$3993.82) Burtons Fire - Air Leak Around Park Brake Parts/Test/Repair (\$86.63) Doug Veerkamp - B Service, Coolant Leak @ lower radiator, Oil Leak at Pan Engine, Air Leak at Compressor, Knock in Floor at Left Turn (\$6027.21) Riebes - Retainer and Rivet Parts (\$12.91) L.N. Curtis - Various Valve Rebuild Kits due to leak (\$168.09)	\$181.00	\$10,498.89
						\$14,372.58	\$90,172.52

AGENDA TRANSMITTAL FORM

<input checked="" type="checkbox"/>	Regular Agenda
<input type="checkbox"/>	Consent Agenda
<input type="checkbox"/>	Blue Slip
<input type="checkbox"/>	Closed Session
Meeting Date Requested:	
04/18/2017	

To: Amador Fire Protection Board of Directors

Date: 04/18/2017

From: David Bellerive Phone Ext. x391
 (Department Head - please type)

Department Head Signature *David Bellerive*

Agenda Title: FEASIBILITY STUDY FOR DISPATCHING SERVICES

Summary: (Provide detailed summary of the purpose of this item; attach additional page if necessary)
 Discussion and possible action relative to the cost of a feasibility study for dispatching services provided by Sacramento Regional Fire/EMS Communications Center. (SRFCC)
 Update to the Board regarding requested information from prior meeting of 3/22/17.

Recommendation/Requested Action:
Authorize staff to proceed with feasibility study

Fiscal Impacts (attach budget transfer form if appropriate) _____ Staffing Impacts _____

Is a 4/5ths vote required? Yes No

Contract Attached: Yes No N/A
 Resolution Attached: Yes No N/A
 Ordinance Attached: Yes No N/A

Committee Review? N/A

Name _____

Committee Recommendation: _____

Comments: _____

Request Reviewed by:

Chairman _____ Counsel _____

Auditor _____ GSA Director _____

CAO _____ Risk Management _____

Distribution Instructions:
n/a

FOR CLERK USE ONLY

Meeting Date 4-18-17 Time 11:00 am Item # 3

Board Action: Approved Yes ___ No ___ Unanimous Vote: Yes ___ No ___

Ayes: _____ Resolution _____ Ordinance _____ Other: _____

Noes _____ Resolution _____ Ordinance _____

Absent: _____ Comments: _____

Distributed on _____

Completed by _____

A new ATF is required from _____ Department _____ For meeting of _____

I hereby certify this is a true and correct copy of action(s) taken and entered into the official records of the Amador Fire Protection District.

ATTEST: _____
 AFPD Board Clerk

AMADOR FIRE PROTECTION DISTRICT

810 Court Street, Jackson California 95642-2132 (209) 223-6391



Date : 4/18/2017
To : Honorable Board of Directors
From : Fire Chief David Bellerive
Re : **Increase of Dispatching Costs**

The 16-17 FY County Budget approved by the Board of Supervisors included \$498,368 for dispatching costs currently provided by Cal Fire, and monies to staff Station 114 in Pine Grove. This budget line item 2440 has not been changed since the 13/14 FY.

Currently these funds are directed to Amador Fire to provide a fire protection resource 24/7/365 out of our Pine Grove Station. Amador Fire utilizes \$258,000 of the original \$498,368 based upon the approval/agreement from the Board of Supervisors.

Due to rising personnel costs, the current contract approved saw a rise in the dispatching costs and a rise in the administration fee. Due to these increases, Amador Fire finds itself with a shortfall and has no other option than to use funds provided for staffing of the station; diverted to pay the increased cost of dispatching. Currently, this increased cost is passed onto Amador Fire, resulting in a shortfall of our current budget.

Attached to this memo are copies of the current and previous dispatching contract as well as the below table showing anticipated costs incurred by Amador Fire over the life of the three (3) year contract. The total cost of the current contract not covered by the approved county Budget Line 2440 is \$132,159. Amador Fire understands the increase however; no other Fire Agency in the County pays for dispatching services.

I brought this issue before the Board of Supervisors at the April 11th 2017 Board meeting. Amador Fire requested the Board of Supervisors to provide additional funding to cover the increased cost of dispatching services through the term of the contract. The Board of Supervisors instructed me and the County Administrative Officer to meet with City and District leaders to discuss the shortfalls in the Dispatching contract.

Per the Boards request, I contacted SRFCC and obtained a "per call" estimated amount of \$45-\$50 per call. Based upon last year's total for the county of 5,400 incidents, this would equate to approximately \$270,000.00. When compared to the amount that is indicated in the Cal Fire contract, there would be a savings to the County in future years. The estimated cost of a complete feasibility study from SRFCC is \$8538.30.

Camino ECC Dispatching Costs

(admin charge 11.49%)			
FY	Cost	Admin	Total
13/14	\$211,369.00	\$24,286.00	\$235,655.00
14/15	\$215,596.00	\$24,772.00	\$240,368.00
15/16	\$219,908.00	\$25,267.00	\$245,175.00
Total	\$646,873.00	\$74,325.00	\$721,198.00

(admin charge 12.79%)				Increase	Shortfall
16/17	\$239,970.00	\$30,692.00	\$270,662.00	\$25,487.00	-\$30,294.00
17/18	\$251,969.00	\$32,227.00	\$284,196.00	\$39,021.00	-\$43,828.00
18/19	\$264,567.00	\$33,838.00	\$298,405.00	\$53,230.00	-\$58,037.00
Total	\$756,506.00	\$96,757.00	\$853,263.00	\$117,738.00	-\$132,159.00

AFPD Feasibility Study- FTE Impacts to SRFECC (Estimate Only)

<u>CAD</u>		<u>Network</u>	
Question Development:	\$ 256.64	Question Development:	\$ 424.24
Site Visit:	\$ 513.28	Site Visit:	\$ 848.48
After Action Report:	\$ 256.64	After Action Report:	\$ 424.24
Total	\$ 1,026.56	Total	\$ 1,696.96
<u>GIS</u>		<u>Dispatch</u>	
Question Development:	\$ 329.76	Question Development:	\$ 415.68
Site Visit:	\$ 659.52	Site Visit:	\$ 831.36
After Action Report:	\$ 329.76	After Action Report:	\$ 415.68
Total	\$ 1,319.04	Total	\$ 1,662.72
<u>Radio</u>		<u>Administrative Cost</u>	
Question Development:	\$ 387.04	Center Car To AFPD HQ:	\$ 43.46
Site Visit:	\$ 774.08	Center Car to Camino Dispatch:	\$ 43.78
After Action Report:	\$ 387.04	Scheduling and Documentation:	\$ 164.88
Total	\$ 1,548.16	Compile Feasibility Report:	\$ 989.28
		Total FTE Impacts	\$ 8,538.30

*Price based on a two day site visit to AFPD HQ and Camino's Dispatch Center.
 *Final product to include a complete feasibility study document

STAFF RECOMMENDATION

While working with the City and District leaders to discuss the shortfalls in the dispatching contract, staff requests that the District moves forward with completing a feasibility study with Sacramento Regional Fire/EMS Communications Center (SRFCC) at the cost of 8538.30. This will provide needed information to ascertain if this option would be financially beneficial to the County for future dispatching services.

EXHIBIT D, SCHEDULE A

FISCAL DISPLAY
 PRC 4142 & 4144

NAME OF LOCAL AGENCY: Amador County

INDEX 2700

PCA Summary

This is Schedule A of Cooperative Agreement originally dated July 1, 2013, by and between the Department of Forestry and Fire Protection of the State of California and LOCAL AGENCY

Original

Amendment for Fiscal Year 2013-2014

		Administrative Charge 11.49%	
TOTAL SCHEDULE A - 4142 - FY 13/14 (PCA 27710) Amador County Dispatch Services	\$ 211,369	\$ 24,286	\$ 235,655
TOTAL SCHEDULE A - 4142 - FY 14/15 (PCA 27710) Amador County Dispatch Services	\$ 215,596	\$ 24,772	\$ 240,368
TOTAL SCHEDULE A - 4142 - FY 15/16 (PCA 27710) Amador County Dispatch Services	\$ 219,908	\$ 25,267	\$ 245,175
DISPATCH SERVICES SUB-TOTAL	\$ 646,873	\$ 74,325	\$ 721,198
TOTAL SCHEDULE A - 4142 - FY 13/14 (PCA 27712) Buena Vista Wildland Mitigation	\$ 796,364	\$ 91,502	\$ 887,866
TOTAL SCHEDULE A - 4142 - FY 14/15 (PCA 27712) Buena Vista Wildland Mitigation	\$ 812,291	\$ 93,332	\$ 905,623
TOTAL SCHEDULE A - 4142 - FY 15/16 (PCA 27712) Buena Vista Wildland Mitigation	\$ 828,537	\$ 95,199	\$ 923,736
TOTAL SCHEDULE A - 4142 - FY 13/14 (PCA 27713) Buena Vista Non-Wildand Mitigation	\$ 1,337,771	\$ 153,710	\$ 1,491,481
TOTAL SCHEDULE A - 4142 - FY 14/15 (PCA 27713) Buena Vista Non-Wildand Mitigation	\$ 1,364,526	\$ 156,784	\$ 1,521,310
TOTAL SCHEDULE A - 4142 - FY 15/16 (PCA 27713) Buena Vista Non-Wildand Mitigation	\$ 1,391,817	\$ 159,919	\$ 1,551,736
BUENA VISTA MITIGATION SUB-TOTAL	\$ 6,531,306	\$ 750,446	\$ 7,281,752
TOTAL CONTRACT	\$ 7,178,179	\$ 824,771	\$ 8,002,950

EXHIBIT D, SCHEDULE A

FISCAL DISPLAY

4142 & 4144

NAME OF LOCAL AGENCY: Amador County

INDEX 2700

PCA Summary

This is Schedule A of Cooperative Agreement originally dated July 1, 2016, by and between the Department of Forestry and Fire Protection of the State of California and LOCAL AGENCY

Original for Fiscal Year 2016-2017

Amendment for Fiscal Year 2016-2017

Administrative Charge (FY16/17 12.79%)
 12.79%

Amador County Dispatch Services			
TOTAL SCHEDULE A - 4142 - FY 16/17 (PCA 27710)	\$	239,970	\$ 30,692 \$ 270,662
Amador County Dispatch Services			
FY 17/18 (PCA 27710)	\$	251,969	\$ 32,227 \$ 284,196
FY 18/19 (PCA 27710)	\$	264,567	\$ 33,838 \$ 298,405
<u>DISPATCH SERVICES SUB-TOTAL</u>	\$	756,506	\$ 96,757 \$ 853,263
Buena Vista Wildland Mitigation			
TOTAL SCHEDULE A - 4142 - FY 16/17 (PCA 27712)	\$	932,380	\$ 119,251 \$ 1,051,631
Buena Vista Wildland Mitigation			
FY 17/18 (PCA 27712)	\$	978,999	\$ 125,214 \$ 1,104,213
FY 18/19 (PCA 27713)	\$	1,027,949	\$ 131,475 \$ 1,159,424
Buena Vista Non-Wildland Mitigation			
TOTAL SCHEDULE A - 4142 - FY 16/17 (PCA 27713)	\$	2,358,997	\$ 301,716 \$ 2,660,713
Buena Vista Non-Wildland Mitigation			
FY 17/18 (PCA 27713)	\$	2,476,947	\$ 316,802 \$ 2,793,749
FY 18/19 (PCA 27713)	\$	2,600,794	\$ 332,642 \$ 2,933,436
<u>BUENA VISTA MITIGATION SUB-TOTAL</u>	\$	10,376,066	\$ 1,327,100 \$ 11,703,166
Total FY 16/17	\$	3,531,347	\$ 451,659 \$ 3,983,006
TOTAL AMOUNT OF CONTRACT	\$	11,132,572	\$ 1,423,857 \$ 12,556,429
Admin Rates 16/17		12.79%	

AGENDA TRANSMITTAL FORM

<input checked="" type="checkbox"/>	Regular Agenda
<input type="checkbox"/>	Consent Agenda
<input type="checkbox"/>	Blue Slip
<input type="checkbox"/>	Closed Session
Meeting Date Requested:	
04/18/2017	

To: Amador Fire Protection Board of Directors

Date: 04/18/2017

From: David Bellerive Phone Ext. x391
(Department Head - please type)

Department Head Signature *David Bellerive*

Agenda Title: Catastrophic Leave Policy

Summary: (Provide detailed summary of the purpose of this item; attach additional page if necessary)

Discussion and possible action on adopting a Catastrophic Leave policy.

Recommendation/Requested Action:
 Approve resolution adopting subject policy, as submitted or amended.

Fiscal Impacts (attach budget transfer form if appropriate) n/a Staffing Impacts n/a

Is a 4/5ths vote required? Yes No

Contract Attached: Yes No N/A
 Resolution Attached: Yes No N/A
 Ordinance Attached: Yes No N/A

Committee Review? N/A

Name _____
 Committee Recommendation: _____

Comments: _____

Request Reviewed by:

Chairman _____ Counsel _____
 Auditor _____ GSA Director _____
 CAO _____ Risk Management _____

Distribution Instructions:
n/a

FOR CLERK USE ONLY

Meeting Date 4-18-17 Time 11:00am Item # 4

Board Action: Approved Yes ___ No ___ Unanimous Vote: Yes ___ No ___
 Ayes: _____ Resolution _____ Ordinance _____ Other: _____
 Noes _____ Resolution _____ Ordinance _____
 Absent: _____ Comments: _____

Distributed on _____
 Completed by _____

A new ATF is required from _____
 Department _____
 For meeting _____
 of _____

I hereby certify this is a true and correct copy of action(s) taken and entered into the official records of the Amador Fire Protection District.

ATTEST: _____
 AFPD Board Clerk

AMADOR FIRE PROTECTION DISTRICT

810 Court Street, Jackson California 95642-2132 (209) 223-6391



Date : 04/18/2017
To : Honorable Board of Directors
From : Ken Woods, Deputy Fire Chief
Re : **Catastrophic Leave Policy**

Staff is requesting the approval of a new "Catastrophic leave" policy for all department members. The policy is similar to one that is currently in use with the County and its purpose is to allow employees to assist fellow employees to continue receiving their benefits. Fellow employees may make donations of vacation and sick leave to those employees who have exhausted their paid leave banks due to a serious/catastrophic or debilitating, illness, injury or condition that affects their ability to work or requires the employee's absence to provide care for an immediate family member.

The policy sets the guidelines and procedures for defining a catastrophic event and the steps required to donate leave. Employees must maintain their own leave bank of a minimum of 100 hours of sick leave and 100 hours of vacation leave after donating. This is to insure that the donating employee has a reserve of hours in case of something that they might experience.

The fire service is a family and we support each other on a daily basis. This policy is an extension of that support and allows employees to provide immediate and tangible assistance to one another through tough times.

BEFORE THE BOARD OF DIRECTORS OF
THE AMADOR FIRE PROTECTION DISTRICT
COUNTY OF AMADOR, STATE OF CALIFORNIA

IN THE MATTER OF:

RESOLUTION APPROVING THE AMADOR
FIRE PROTECTION DISTRICT
CATASTROPHIC LEAVE POLICY

RESOLUTION NO. AFD 17-

BE IT RESOLVED by the Board of Directors of the Amador Fire Protection District, County of Amador, State of California, that said Board does hereby approve the Amador Fire Protection District Catastrophic Leave policy.

BE IT FURTHER RESOLVED that the President be and hereby is authorized to sign the resolution approving to this policy manual.

The foregoing resolution was duly passed and adopted by the Board of Directors of the Amador Fire Protection District at a regular meeting thereof, held on the 18th day of April, 2017, by the following vote:

AYES:

NOES:

ABSENT:

President, Board of Directors

ATTEST:

LINDSEY CLARK, Clerk of the
Amador Fire Protection District,
Amador County, California

AMADOR FIRE PROTECTION DISTRICT



Policies and Procedures

Policy 1.E.6

Catastrophic Leave

1.0 Statement of Intent

To assist employees who have exhausted paid leave banks due to a serious/catastrophic or debilitating, illness, injury or condition affecting their own ability to work or requiring the employee's absence to provide care for an immediate family member. This policy establishes procedures for the maintenance of Catastrophic Leave and the processing of requests for donations.

2.0 Assigned Responsibility

Applicable to all paid personnel

3.0 Applicability

Circumstances described within the policy

4.0 Definitions

Catastrophic Event A catastrophic illness or injury diagnosed by a licensed physician, requiring an extended period of treatment or recuperation or which has a significant risk to life expectancy. This policy may be used in conjunction with the Federal and State Family Leave laws.

Immediate Family Parent, stepparent, foster parent, grandparent, brother, stepbrother, sister, stepsister, spouse, child, stepchild, foster child, grandchild, uncle, aunt, nephew, niece, mother-in-law, father-in-law, brother-in-law,

sister-in-law, son-in-law, daughter-in-law of an employee. Other relatives and significant persons may be included with the approval of the Fire Chief.

Eligible Member Any regular full-time employee who has completed his/her probationary period and has liquidated all available paid leave for which he/she is otherwise eligible (i.e. vacation, sick leave) and has suffered a catastrophic event.

Receiving Employee Regular fulltime employee who has passed probation and meets the requirements for having a catastrophic event

Donating Employee A regular fulltime employee who has passed probation and has completed a voluntary request to transfer annual leave to fellow employees.

12- month period Defined as a 12-month period measured from the date an employee first receives donated hours.

5.0 Procedures

A. For Receiving employees:

1. Employee must be a full time employee.
2. Employee must have exhausted all paid leave balances.
3. Employee must have a catastrophic event as defined above.
4. The Fire Chief or his designee may require submission of documents to support the determination of a catastrophic event prior to approval of the request.
5. Employee must be prevented from returning to work for at least 30 calendar days and be eligible for long-term disability benefits or family leave.
6. Employee cannot receive leave when his/her employment status would prevent continuation of active leave benefits.

7. The medical prognosis for the condition includes reasonable expectation that proper care and rehabilitation will result in the return of the employee to full duties.
8. An eligible employee shall make a written request to the Fire Chief stating the nature of the catastrophic event which necessitates the need for the leave. Such request will also include a statement that may be released to all potential donors regarding the nature of the request.
9. No leave will be paid until the employee has liquidated all of their paid leave which accrued prior to the donations.
10. While on leave status, District benefits will continue per applicable law.
11. A receiving employee may not receive donated leave that allows a continuing leave of absence status if a decision would have otherwise been made concerning the employment status of the employee.

B. For Donating employees:

1. Employee must be a full time employee and must retain a minimum balance of 100 hours of sick leave and 100 hours of vacation after donating.
2. Employees must donate a minimum of twelve (12) hours.
3. District office staff shall send a notice to all potential donors of the statement that the Requestor has authorized to be disclosed regarding the catastrophic event.
4. A donating employee must complete the donation form and forward it to the District office for processing. Once approved, office staff will use the date and time approved to track the donation. Donated leave will be credited to the receiving employee from donating employees in chronological order by the date submitted for approval and used only as needed. If there are simultaneous requests to donate, the hours needed, will be evenly divided between donating parties.
5. Participation by regular employee's (both donating and receiving) shall be voluntary and only where there is a catastrophic event as defined above.
6. Donors shall be notified that only vacation and/or sick leave may be donated and that donations will go directly to the Requestor in the order of the date received and any unused donations will be returned to the donor(s).
7. Donated leave shall be converted in the following manner: the donating employee's hours shall be converted to a dollar amount using base salary, then, re-converted to the receiving employees hours using base salary.

8. Once the leave is donated and posted to the receiving employee, the employee donating such leave shall irrevocably lose all rights and privileges to the leave hours donated.
9. Donated leave cannot be used for longer than twelve (12) months, when donated leave is exhausted, or a change in employment status occurs, whichever comes first.

6.0 Appendices

None

7.0 Reference

None

8.0 Monitoring and Review

The Fire Chief shall review this policy every three years.

Approved By:

David Bellerive, Fire Chief

Amador Fire Protection District

Revisions:

Drafted 1/21/17 Ken Woods, Deputy Chief

Revised

Distribution List: Policy Manual

AGENDA TRANSMITTAL FORM

To: Amador Fire Protection Board of Directors

Date: 04/18/2017

From: David Bellerive Phone Ext. x391
(Department Head - please type)

Department Head Signature *David Bellerive*

<input checked="" type="checkbox"/>	Regular Agenda
<input type="checkbox"/>	Consent Agenda
<input type="checkbox"/>	Blue Slip
<input type="checkbox"/>	Closed Session
Meeting Date Requested:	
<u>04/18/2017</u>	

Agenda Title: PURCHASE OF FIRE APPARATUS

Summary: (Provide detailed summary of the purpose of this item; attach additional page if necessary)

Discussion and possible action regarding the purchase of a 2017 Rosenbauer Type 1 Engine.

Recommendation/Requested Action:

Approve resolution for purchasing and financing the subject vehicle.

Fiscal Impacts (attach budget transfer form if appropriate) _____ Staffing Impacts n/a

Is a 4/5ths vote required? Yes No

Contract Attached: Yes No N/A
 Resolution Attached: Yes No N/A
 Ordinance Attached: Yes No N/A

Committee Review? Name _____ N/A

Committee Recommendation: _____

Comments: _____

Request Reviewed by:

Chairman _____ Counsel _____
 Auditor _____ GSA Director _____
 CAO _____ Risk Management _____

Distribution Instructions: _____

FOR CLERK USE ONLY

Meeting Date 4-18-17 Time 11:00am Item # 5

Board Action: Approved Yes ___ No ___ Unanimous Vote: Yes ___ No ___

Ayes: _____ Resolution _____ Ordinance _____ Other: _____

Noes: _____ Resolution _____ Ordinance _____

Absent: _____ Comments: _____

Distributed on _____ Completed by _____	A new ATF is required from _____ Department _____ For meeting _____ of _____	I hereby certify this is a true and correct copy of action(s) taken and entered into the official records of the Amador Fire Protection District. ATTEST: _____ AFPD Board Clerk
--	---	--

AMADOR FIRE PROTECTION DISTRICT

810 Court Street, Jackson California 95642-2132 (209) 223-6391



Date : 04/18/2017
To : Honorable Board of Directors
From : Ken Woods, Deputy Fire Chief
Re : **Purchase of a 2017 Rosenbauer Type 1 Engine to replace E141 at station 114**

Per the Boards direction at the 6/21/16 Board meeting to sell E111 and purchase a replacement engine, staff is recommending the purchase of a 2017 Rosenbauer Type 1 Engine for a total price of \$548,949.

E141, a 2003 HME engine is currently utilized as the first out engine at station 114 in Pine Grove. E141 is reaching its 15 year service life as a first out engine and would be moved to station 122 in Plymouth and placed in service as a reserve apparatus replacing a 1991 KME engine that currently serves as the reserve engine.

The purchase of a new engine will greatly enhance the District's emergency response capabilities from station 114. This new engine is equipped with four wheel drive enabling it to rapidly respond to emergency calls in the snow without having to stop and chain up as is currently required with engine 141 (2-wheel drive). The new engine would be equipped with the latest NFPA safety features and would have increased compartment space allowing it to carry a full complement of firefighting equipment. Currently equipment at station 114 is carried on two separate units, E141 and squad 145.

Staff performed extensive research into the type, size and requirements of a new Type 1 engine, meeting with manufacturers. Based on the developed requirements, staff then utilized the National Joint Powers Alliance (NJPA) to obtain national contract group volume pricing from national vendors which competitively bid on fire apparatus to obtain the lowest cost for the requested engine. Other California fire agencies including Madera, Napa and Tuolumne Counties, City of Stockton and other cities have recently used the pricing available through NJPA to purchase engines for their jurisdictions due to the competitive bidding process.

Rosenbauer Fire Apparatus met the department's requirements for the engine and the lowest pricing was obtained through the NJPA bid process. Additionally Amador Fire's two most recent apparatus purchases, E5111 and E5361 have both been manufactured by Rosenbauer and purchased through Burton's Fire Inc. in Modesto, who also performs the warranty and service/repair work on these vehicles. The purchase of an additional Rosenbauer will reinforce the commonality of like apparatus/parts and provide more effective processing of service and repair requests by eliminating multiple manufacturers and vendors. To date staff has been pleased with the service received from Burton's and they have been very responsive to our warranty and service request needs

Staff obtained three financing quotes for the purchase of the apparatus. If the department purchases the vehicle chassis prior to construction, it will receive a \$9,531 discount. Based on the financing rates available, staff is recommending signing the purchase contract with Rosenbauer and a down payment of \$248,312 (\$230,000 from the sale of E111) which equals the prepayment cost for the chassis. The department would then finance the remaining \$300,637 for a term determined by the Board.

Note: Per the Boards prior direction the previous engine (E5111) was financed by the District in 2016 at a 10-year

term with an interest rate of 2.79% interest and due to continuing favorable interest rates, staff is recommending the financing of this new engine at the same 10-year term at a rate of 3.22% interest with no closing costs or fees.

BEFORE THE BOARD OF DIRECTORS OF THE
AMADOR FIRE PROTECTION DISTRICT
COUNTY OF AMADOR, STATE OF CALIFORNIA

IN THE MATTER OF:

RESOLUTION APPROVING PURCHASE
OF 2017 ROSENBAUER TYPE 1, ENGINE

RESOLUTION NO. 17-

BE IT RESOLVED by the Board of Directors of the Amador Fire Protection District, that said Board does hereby approve the purchase of one 2017 Rosenbauer Type 1 Engine in the amount of \$548,949.00 from Burton's Fire Inc. With a down payment on the chassis of \$248,312.00 and \$300,637.00 to be financed from Community Leasing at 3.22% interest over a 10 year term with 1 payment per year in arrears.

BE IT FURTHER RESOLVED that the President of said Board is hereby authorized to sign and execute all documents deemed necessary to complete the transaction on behalf of the Amador Fire Protection District.

The foregoing resolution was duly passed and adopted by the Board of Directors of the Amador Fire Protection District at a regular meeting thereof, held on the 18th day of April, 2017, by the following vote:

AYES:

NOES:

ABSENT:

President, Board of Directors

ATTEST:

LINDSEY CLARK, Clerk of the
Amador Fire Protection District,
Amador County, California

- NOTES:**
1. OVERALL HEIGHT IS IN LOADED CONDITION. UNLOADED HEIGHTS MAY BE 4" ABOVE HEIGHTS SHOWN.
 2. DO NOT SCALE DRAWING.
 3. ALL DIMENSIONS ARE APPROXIMATE AND SUBJECT TO ENGINEERING CHANGES.
 4. DRAWINGS MAY OR MAY NOT SHOW ALL ITEMS AS DESCRIBED IN THE WRITER DETAIL SPECIFICATIONS.
 5. INCLUSION OF AN ITEM ON THE DRAWING DOES NOT CONSTITUTE INCLUSION OF THAT ITEM WITH THE FINAL DELIVERED UNIT.
 6. THE EFFECTIVE DOOR OPENINGS WILL BE APPROX. 2" LESS THAN THE NOTED DIMENSIONS. DIMENSIONS FOR HINGED DOORS AND UP TO APPROX. 4" LESS FOR HINGED DOORS.

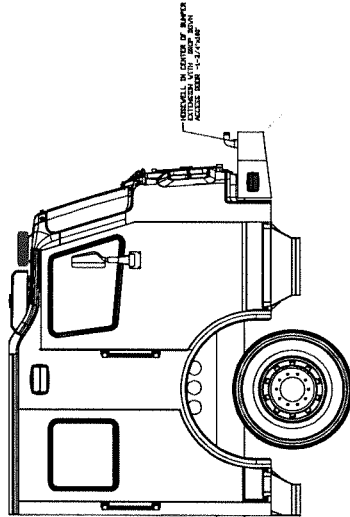
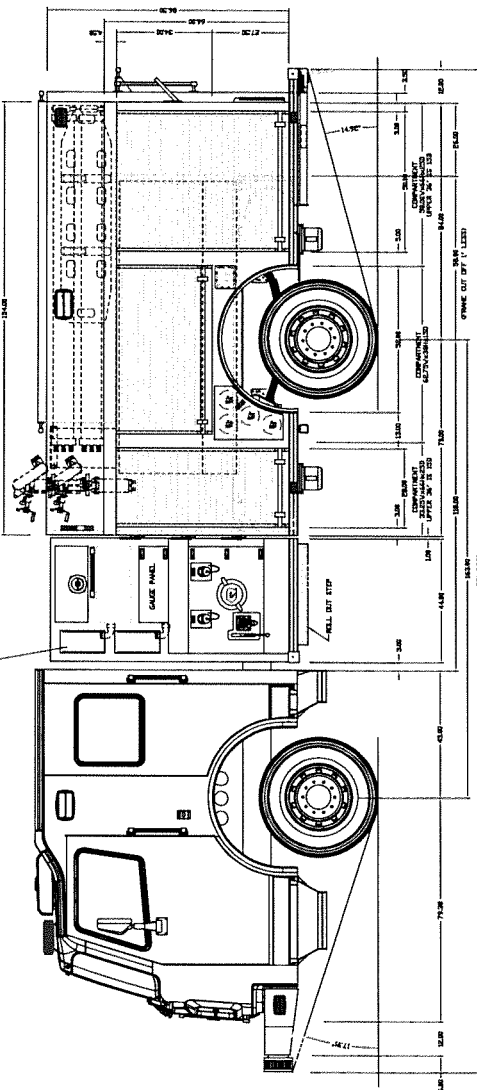
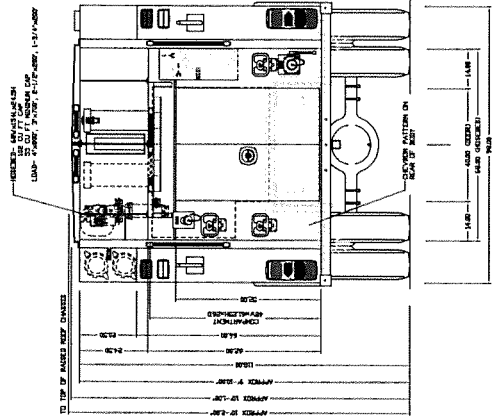

AMADOR FIRE TYPE 1 ENGINE PURCHASE - FINANCING OPTIONS

Engine (body price)	\$267,231.00
Engine (Chassis price)	\$248,312.00
Chassis prepay discount	-\$9,531.00
Delivery (non taxable)	\$3,721.00
Sales Tax (7.75%)	\$39,216.00
Total Price	\$548,949.00
Chassis pre-pay (down payment)	-\$248,312.00
Total Amount to be Financed	\$300,637.00

LENDER

Community Leasing

	<u>5-year</u>	<u>7-year</u>	<u>10-year</u>
Annual Payment	\$65,446.91	\$48,334.20	\$35,647.90
Interest Rate	2.89%	3.04%	3.22%
Total Cost	\$327,234.55	\$338,339.40	\$356,479.00

Republic First National

	<u>5-year</u>	<u>7-year</u>	<u>10-year</u>
Annual payment	\$65,767.85	\$48,550.61	\$35,776.79
Interest rate	3.05%	3.15%	3.29%
Total cost	\$328,839.25	\$339,854.27	\$357,767.90

Rosenbauer

	<u>5-year</u>	<u>7-year</u>	<u>10-year</u>
Annual payment	\$66,261.59	\$48,939.33	\$36,130.90
interest rate	3.33%	3.38%	3.49%
Total Cost	\$331,307.95	\$342,575.31	\$361,309.00

To: **AMADOR FIRE PROTECTION DISTRICT**
810 COURT STREET
JACKSON, CA. 95642

DATE: 3/30/2017

We hereby propose and agree to furnish, after your acceptance of this proposal and the proper execution by the Amador FPD, hereinafter called the BUYER and an officer of Rosenbauer South Dakota, LLC, hereinafter called the COMPANY, the following apparatus and equipment:

(1) ONE ROSENBAUER TYPE 1 FX BODY ROSENBAUER SOUTH DAKOTA, LLC	\$267,231.00
(1) ONE ROSENBAUER COMMANDER WARRIOR CHASSIS	\$248,312.00
DELIVERY EXPENSE (NON-TAXABLE)	\$3,721.00
CHASSIS PRE-PAY DISCOUNT	(\$9,531.00)
CALIFORNIA STATE SALES TAX 7.75%	<u>\$39,216.00</u>
TOTAL ...	\$548,949.00*

FIVE HUNDRED FORTY EIGHT THOUSAND NINE HUNDER FORTY NINE DOLLARS

All of which are to be built in accordance with the specifications, clarifications and exceptions attached, and which are made a part of this agreement and contract.

DELIVERY: The estimated delivery time for the completed apparatus, is to be made 365 days after receipt of and approval of this contract duly executed, subject to all causes beyond the Company's control. The quoted delivery time is based upon our receipt of the specified materials required to produce the apparatus in a timely manner. The Company cannot be held responsible for delays due to Acts of God, Labor Strikes, or Changes in Governmental Regulations that result in delayed delivery to our manufacturing facilities of these specified materials. This delivery estimate is based on the Company receiving complete and accurate paperwork from the Buyer and that no changes take place during pre-construction, mid-point inspections or final inspections. Changes required or requested by the Buyer during the construction process may be cause for an increase in the number of days required to build said apparatus.

PAYMENT TERMS: Final payment for the apparatus shall be made at time of delivery or pick up of the completed vehicle. It is the responsibility of the Buyer to have full payment ready when the apparatus is complete and ready to deliver. If payment is delayed or delivery is delayed pending payment, a daily finance and storage fee may apply. Upon delivery of the apparatus or upon pickup of the apparatus by the Buyer, Buyer agrees to provide all liability and physical damage insurance. It is further agreed that if on delivery and test, any defects should develop, the Company shall be given reasonable time to correct same. Guarantee of the chassis is subject to the guarantee of the chassis manufacturer.

MISCELLANEOUS PROVISIONS: This agreement shall be construed in accordance with the laws of the State of South Dakota. The parties agree that any litigation arising from or in connection with any dispute between the parties under this agreement shall be venued in South Dakota. The parties agree that this agreement bears a rational relationship to the State of South Dakota, and they consent to the personal jurisdiction of such state and further consent and stipulate to venue in the above described court.

*NOTE: TOTAL PRICE INCLUDES CHASSIS PRE-PAY DISCOUNT THAT IS DUE IN 150 DAYS AFTER THE ORDER IS PLACED.

The amount in this proposal shall remain firm for a period of 30 days from the date of same.

Respectfully submitted,

DEALER: BURTON'S FIRE, INC.

SALES REP: _____

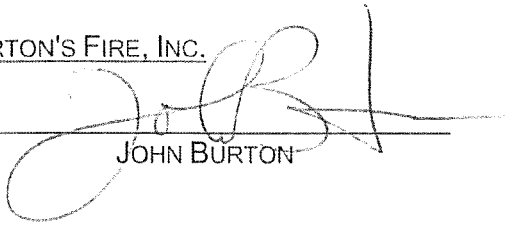

JOHN BURTON

BUYER:

We accept the above proposal and enter into contract with signature below:

_____ Title _____
_____ Title _____
_____ Date _____

After company receipt of this document signed by the Buyer, the document will be reviewed and upon approval, countersigned by the Company thereby putting the document in force.

ROSENBAUER SOUTH DAKOTA, LLC

_____ Title _____
_____ Date _____

AGENDA TRANSMITTAL FORM

To: Amador Fire Protection Board of Directors

Date: 04/18/2017

From: David Bellerive Phone Ext. 391
 (Department Head - please type)

Department Head Signature *David Bellerive*

<input checked="" type="checkbox"/>	Regular Agenda
<input type="checkbox"/>	Consent Agenda
<input type="checkbox"/>	Blue Slip
<input type="checkbox"/>	Closed Session
Meeting Date Requested:	
<u>04/18/2017</u>	

Agenda Title: Self Contained Fuel Tank for Station 112

Summary: (Provide detailed summary of the purpose of this item; attach additional page if necessary)

Discussion and possible action relative to the placement of a 1,000 gallon fuel tank at station 112.

Recommendation/Requested Action:
Approve placement and use of a 1,000 gallon fuel tank at station 112.

Fiscal Impacts (attach budget transfer form if appropriate) None Staffing Impacts None

Is a 4/5ths vote required? Yes No

Contract Attached: Yes No N/A
 Resolution Attached: Yes No N/A
 Ordinance Attached: Yes No N/A

Committee Review? N/A

Name _____

Committee Recommendation: _____

Comments: _____

Request Reviewed by:

Chairman _____ Counsel _____

Auditor _____ GSA Director _____

CAO _____ Risk Management _____

Distribution Instructions: _____

FOR CLERK USE ONLY

Meeting Date 4-18-17 Time 11:00am Item # 6

Board Action: Approved Yes ___ No ___ Unanimous Vote: Yes ___ No ___

Ayes: _____ Resolution _____ Ordinance _____ Other: _____

Noes _____ Resolution _____ Ordinance _____

Absent: _____ Comments: _____

Distributed on _____

Completed by _____

A new ATF is required from _____ Department _____ For meeting _____ of _____

I hereby certify this is a true and correct copy of action(s) taken and entered into the official records of the Amador Fire Protection District.

ATTEST: _____
 AFPD Board Clerk

AMADOR FIRE PROTECTION DISTRICT

810 Court Street, Jackson California 95642-2132 (209) 223-6391



Date : April 18, 2017
To : Honorable Board of Directors
From : Ken Woods, Deputy Fire Chief
Re : **Self-Contained Fuel Tank for Station 112**

Staff is requesting the placement of a 1,000 gallon fuel tank at station 112 in support of the day to day operations and for continuity of emergency services. This request is being made due to recent changes and problems encountered in obtaining diesel fuel for our apparatus. Currently in Pioneer, diesel fuel is available only at the Trading Post-Shell, the station at Amador Pines, and in Pine Grove the 76 station is no longer open for fuel purchase. The other remaining station in Pine Grove charges extremely high prices for diesel fuel.

Over the past few months the Shell station in Pioneer has run out of fuel several times and has experienced problems with their pumps whereby they were out of service for several days at a time requiring the apparatus at station 111 to travel to Pine Grove for fuel. The Amador Pines station is available but at a higher price. Effective this month the 76 station in Pine Grove no longer provides fuel thereby complicating the issue of purchasing fuel locally.

This leaves the only alternative for obtaining diesel fuel being in Jackson which is a long distance with extended travel times from both Pioneer and Pine Gove and this takes apparatus away from their normal response jurisdictions.

Also due to the recent storms we have seen temporary closures of Hwy 88 due to downed trees and power lines and the complete closure of roads, such as Hwy 26 due to road surface failure. We do not want to find ourselves in a situation where we are unable to obtain fuel for an extended length of time or are cut off from available fuel sources.

Combined monthly diesel fuel usage for stations 111 & 112 (Pioneer) and station 114 (Pine Grove) were approximately 800 to 1000 gallons. Staff researched the possibility of obtaining a fuel tank for placement at station 112. We received quotes for a 1000 gal above ground self-contained tank, with the lowest being \$6066.29 (incl. tax). Staff also contacted Hunt & Sons, a Sacramento based

distributor who currently delivers within Amador County and they will provide us with a 1,000 gallon tank at no charge as long as we purchase fuel from them. Their current price per gallon of diesel effective 4/8 was 2.72/gallon (incl. tax). Current diesel price per gallon for the Shell station in Pioneer was \$2.96.

Staff has met with County Environmental Health and their only requirement is that the District annually report the tank information to the Statewide CUPA (Certified Unified Program Agency). Additionally Staff met with County Building department who advised that we would need a one-time building permit and to comply with the California Fire code and NFPA which specify the location of the tank and placement of vehicle impact protection. Annually the District would then be responsible for inspections of the tank. Currently staff is inquiring on obtaining used K rails from Cal Trans.

Additionally staff contacted the property owner of station 112 who authorized the placement of an above ground self-contained tank at that location.

Staff is requesting approval for the placement and use of a 1,000 gallon diesel fuel tank from Hunt and Sons placement at station 112 where it can be easily accessed by stations 111, 112 and 114.

Vaulted Fuel Storage Systems



SMALL



2085 Listed
"Protected" Type

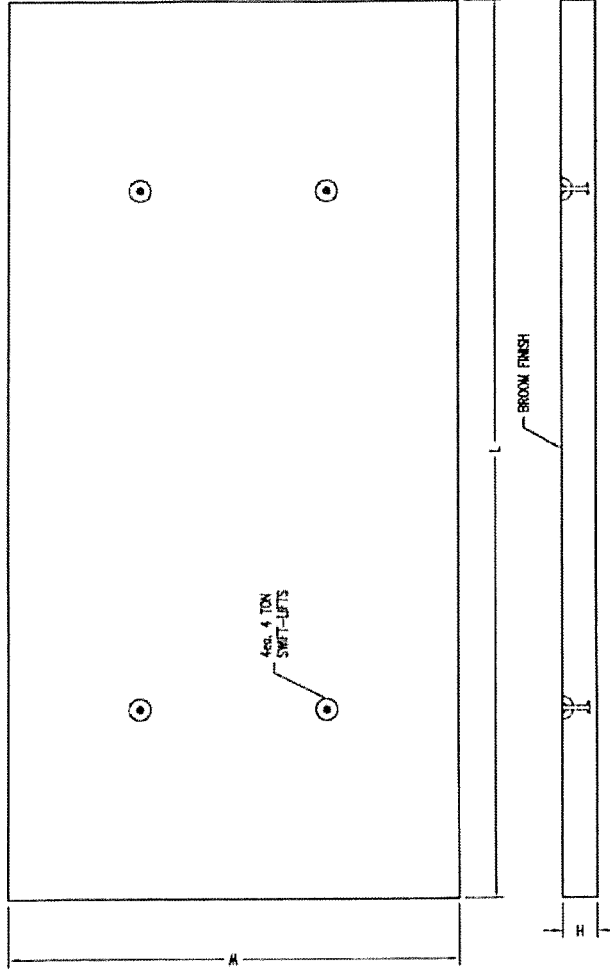

- GENERAL NOTES FOR CONVAULT PAD :
1. CONCRETE: $f_c = 4,500$ psi ULTIMATE COMPRESSIVE STRENGTH IN 28 DAYS.
 2. REINFORCEMENT: A. REBAR: ASTM A706, GRADE 60
B. STRENGTH $F_y = 60,000$ psi.
 3. STRUCTURE DESIGNED FOR EQUIPMENT LOADING

MODEL	W	L	H	WEIGHT
CVS-250-F-6	5'-9"	9'-8"	6"	4,250 lbs
CVS-500-F-6	6'-6"	13'-0"	6"	6,450 lbs
CVS-1000-F-6	7'-8"	13'-0"	6"	7,600 lbs
CVS-2000-F-6	10'-0"	13'-3"	6"	10,150 lbs

Small Precast Foundation Slab

AGENDA TRANSMITTAL FORM

To: Amador Fire Protection Board of Directors

Date: 04/18/2017

From: David Bellerive Phone Ext. x391
(Department Head - please type)

Department Head Signature *David Bellerive*

<input checked="" type="checkbox"/>	Regular Agenda
<input type="checkbox"/>	Consent Agenda
<input type="checkbox"/>	Blue Slip
<input type="checkbox"/>	Closed Session
Meeting Date Requested:	
<u>04/18/2017</u>	

Agenda Title: MINUTES

Summary: (Provide detailed summary of the purpose of this item; attach additional page if necessary)

Review and approval of the Board of Directors regular minutes of March 22, 2017 as presented or revised.

Recommendation/Requested Action:
Approve minutes as presented or revised

Fiscal Impacts (attach budget transfer form if appropriate) n/a Staffing Impacts n/a

Is a 4/5ths vote required? Yes <input type="checkbox"/> No <input checked="" type="checkbox"/>	Contract Attached: Yes <input type="checkbox"/> No <input type="checkbox"/> N/A <input checked="" type="checkbox"/> Resolution Attached: Yes <input type="checkbox"/> No <input type="checkbox"/> N/A <input checked="" type="checkbox"/> Ordinance Attached: Yes <input type="checkbox"/> No <input type="checkbox"/> N/A <input checked="" type="checkbox"/> Comments: _____ _____
Committee Review? Name _____ N/A <input checked="" type="checkbox"/> Committee Recommendation: _____ _____	

Request Reviewed by:

Chairman _____ Counsel _____

Auditor _____ GSA Director _____

CAO _____ Risk Management _____

Distribution Instructions:
n/a

FOR CLERK USE ONLY

Meeting Date 4-18-17 Time 11:00am Item # 7

Board Action: Approved Yes ___ No ___ Unanimous Vote: Yes ___ No ___

Ayes: _____ Resolution _____ Ordinance _____ Other: _____

Noes: _____ Resolution _____ Ordinance _____

Absent: _____ Comments: _____

Distributed on _____ Completed by _____	A new ATF is required from _____ Department _____ For meeting _____ of _____	I hereby certify this is a true and correct copy of action(s) taken and entered into the official records of the Amador Fire Protection District. ATTEST: _____ AFPD Board Clerk
--	---	--

**AMADOR FIRE PROTECTION DISTRICT
BOARD OF DIRECTORS**

Meeting Recorded
On MP3
No. AFD 17-03

Jackson, California
Wednesday, March 22, 2017
1:32p.m.

The Board of Directors of the Amador Fire Protection District met in the County Administration Center, 810 Court Street, Jackson, California, on the above date pursuant to adjournment, and the following proceedings were had, to wit:

Present:

Richard M. Forster, President, Director
Lynn Morgan, Vice President, Director
Brian Oneto, Director
Pat Crew, Director
Frank Axe, Director

Staff:

David Bellerive, Fire Chief
Lindsey Clark, Clerk of the Board
Nicole Cook, Administrative Assistant

AGENDA

MOTION: It was moved by Director Crew, seconded by Director Morgan, and carried to approve the agenda, as presented.

Absent: Director Oneto

PUBLIC MATTERS NOT ON THE AGENDA: Chief Dominic Moreno of Sutter Creek Fire Protection District (SCFPD) provided an update to the Board of the intention of SCFPD to build a new fire station in Sutter Hill with the possible increase of AFD staff from 1-0 staffing to 2-0 staffing.

Chief David Bellerive provided a personnel and community service update to the Board, giving special recognition to Captain Jones, Engineer Herrera, and Firefighter Terrones for their diligence on a repetitive incident in Pine Grove, as well as Battalion Chief Antonio Moreno for doing an excellent job coordinating and executing a successful training burn.

At 1:37p.m. Director Oneto took his seat.

Chief David Bellerive reviewed with the Board various grants, community service projects, and the status of the Districts current firefighter academy.

ADMINISTRATIVE MATTERS

Vehicle Maintenance Report: The Board reviewed the February maintenance report. Discussion ensued regarding possibilities of having a county wide fire mechanic. Staff Directed to perform a feasibility study on having a district mechanic.

Update to Board for Regular Rate of Pay: Chief Bellerive reviewed the regular rate of pay update with the Board.

Surplus Property: Chief Bellerive reviewed with the Board the past three years of maintenance history for engine 124, and requested to offer the engine to local agencies as a donation and then if it was not wanted locally to take it to public auction. Discussion ensued regarding the value of the engine and what vehicle would be used in place of engine 124.

MOTION: It was moved by Director Oneto, seconded by Director Morgan and unanimously carried to approve the surplus of engine 124 by first offering it as a donation to other local fire agencies, second to local non fire agencies, and then to be sold at public auction.

Feasibility Study for Dispatching Services: Chief Bellerive reviewed the request and reasoning for a feasibility study for dispatching services provided by Sacramento Regional Fire/EMS Communications Center (SRFCC). Discussion ensued regarding the increasing costs of the current contract. Direction to staff to obtain detailed report of current contract increases as well as a cost per call for other agencies using SRFCC services.

Change in Procedure for Benefit Assessment: Chief Bellerive reviewed with the Board the time and cost savings for the District if the contiguity factor were removed will completing the annual benefit assessments. Discussion ensued as to why this practice is in place and what defines a parcel as contiguous. Direction to staff to have this topic reviewed by County Counsel and bring back to the next meeting.

FY 2017/2018 Benefit Assessment: Chief Bellerive reviewed with the Board the request to update the 2017/2018 benefit assessment Exhibit A by 2% as allowed by the ordinance.

MOTION: It was moved by Director Oneto, seconded by Director Morgan and unanimously carried to approve the increase of Exhibit A for the benefit assessments by 2%

Request for Additional Battalion Chief Position: Chief Bellerive reviewed a memo of request for an additional Battalion Chief position to be paid for by the Jackson Rancheria with the Board. Discussion ensued regarding the District's long term plan for chief officers, the funding of this additional position, the Districts organizational chart, and the essential job duties of a Battalion Chief.

During open comment the following people spoke regarding this subject and why they did or did not support it. Lengthy discussion ensued.

Chief Dominic Moreno – Sutter Creek Fire Protection District
Director Hal Gamble – Sutter Creek Fire Protection District Board of Directors
Fire Chief David Bellerive – Amador Fire Protection District
Deputy Fire Chief Ken Woods – Amador Fire Protection District
Battalion Chief Chad Marino – Amador Fire Protection District
Battalion Chief Aaron Watkins – Amador Fire Protection District
Battalion Chief Keith Brizzi – Amador Fire Protection District
Firefighter Shaun Gonsalves – Amador Fire Protection District

MOTION: It was moved by Director Crew, seconded by Director Morgan and approved to hire an additional Battalion Chief to be paid for by the Jackson Rancheria, and move District Battalion Chief's to a 48/96 schedule.

Noes: Director Oneto
MISCELLANEOUS MATTERS

Minutes of February 21, 2017:

MOTION: It was moved by Director Oneto, seconded by Director Axe, and carried to approve the minutes of February 21, 2017 as presented.

ADJOURNMENT: At 4:49p.m., President Forster adjourned the meeting until **Tuesday, April 18, 2017 at 11:00a.m.**

President, Amador Fire Protection District